

REV	REVISION DATE	RELEASE NUMBER	DESCRIPTION	DRAWN BY	CHECKED BY	APPROVED BY
A	1-17-94		7302-99-00 WAS 155-44-10	JGL		
B	2-7-94		1.668 WAS 1.687. .834 WAS .844 13.7° WAS 15°	JGL		
C	7-14-94		.090 WAS .070. 1.640 WAS 1.668 1.08 WAS 1.093. MODIFIED LATCH DETAIL	JGL		
00	10-27-99	2155	REDRAWN ON CADD6	SJB	JCB	REF
01	2-03	3149	UPDATED MATERIAL NO.	SJB	JCB	REF

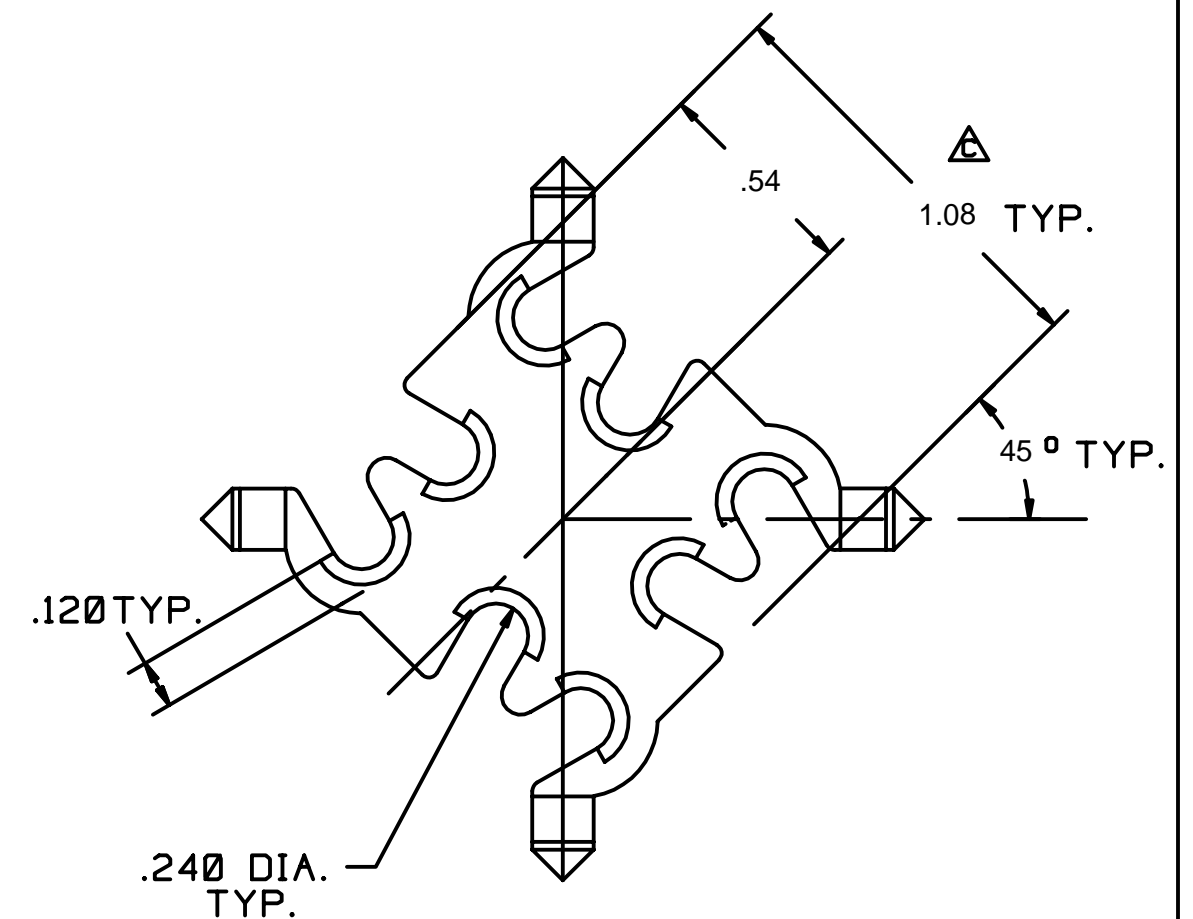
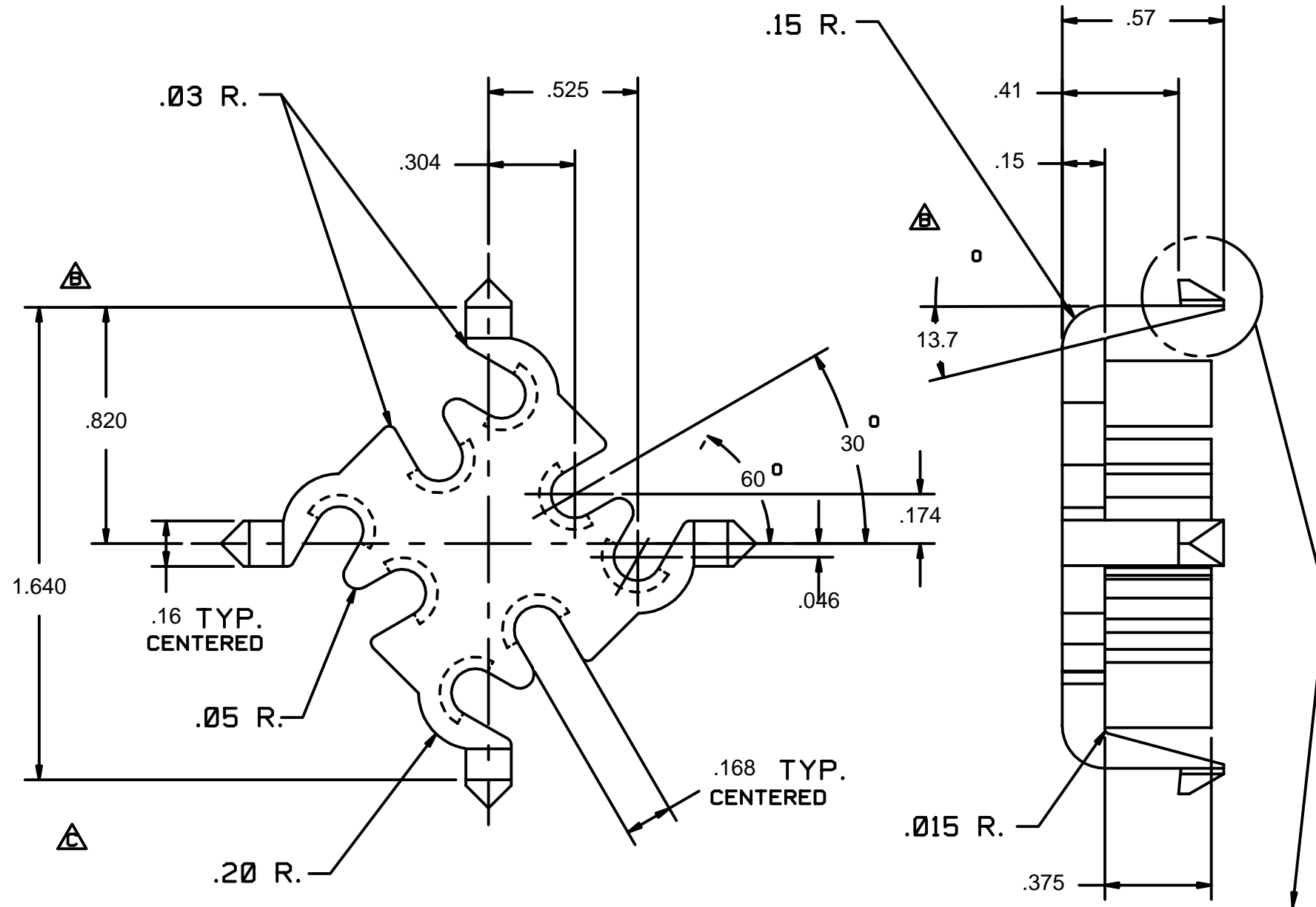

FARGO NO. PT-059222
FARGO NO. PT-059222 GN

NOTES:

1- MATERIAL: NYLON 6-6.
FARGO #CP-N66YELHT (YELLOW)
#CP-66NAT & NYCCGRN (GREEN)

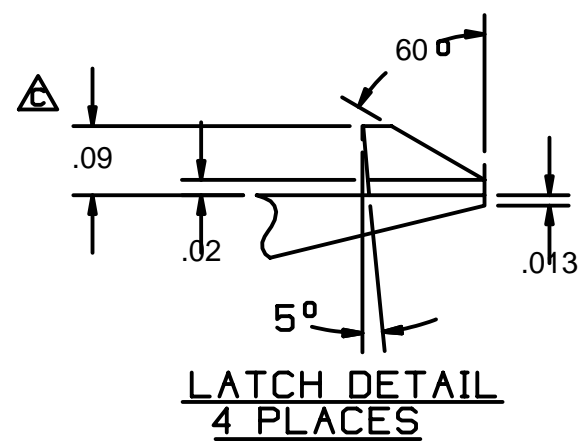

FILE # 991027-2	SHEET 1 OF 1	FARGO ASSEMBLY OF PA
UNLESS STATED OTHERWISE: DIMENSIONS ARE IN INCHES. AND TOLERANCE ARE:	THIRD ANGLE PROJECTION	P.O. BOX 550 NORRISTOWN, PA 19404 PHONE: 610-272-6850 FAX: 610-272-6858
.X +/- .020	DRAWN DATE 10-26-99	OUR COMPANY GOALS 1. QUALITY 2. DELIVERY 3. FAIR PRICE 4. GOLDEN RULE
.XX +/- .010	CHECKED DATE JCB 10-99	ELECTRICAL SYSTEMS ASSEMBLY AND DESIGN
.XXX +/- .005	APPROVED DATE REF 10-99	TITLE: RETAINER CLIP SEALED MINI FUSE BLOX
FRACTIONAL +/- 1/64	SCALE: 2 X 1	DRAWING NUMBER 7302-99-00
ANGULAR +/- 30 MIN		REVISION 01
THIS DOCUMENT CONTAINS PROPRIETARY INFORMATION AND IS NOT TO BE USED IN ANY WAY DETRIMENTAL TO THE INTEREST OF FARGO ASSEMBLY OF PA, INC.		